



SCAFOM

SCAFOM.IN

Providing High Strength,
Modular Ringlock
Scaffolding Solutions



Ringlock Scaffolding

- 1. Innovative Design:** Features a unique rosette connection that enables quick, multi directional assembly.
- 2. High Efficiency:** The Modular structure allows for faster erection and dismantling, reducing labor time and costs.
- 3. Exceptional Strength:** Engineered for superior load bearing capacity, ensuring structural stability.
- 4. Versatile Applications:** Ideal for complex construction, industrial, and infrastructure geometries.
- 5. Global Popularity:** Also known as Ring Lock, Disc Lock, or All Round Scaffolding, widely used across industries.
- 6. Cost Effective:** Designed for long term use with minimal maintenance, maximizing return on investment.
- 7. User Friendly:** Simplifies assembly with fewer components, improving on site productivity.
- 8. Enhanced Safety:** Meets international construction standards for secure and reliable scaffolding solutions.



Staging & Support Scaffolding

Ringlock scaffolding is widely used as staging and support scaffolding in construction, especially for heavy loads like concrete formwork, bridges, and industrial structures. It provides high load bearing capacity due to its modular design and rosette based connections, ensuring even weight distribution and structural stability.

Why Use Ringlock for Staging & Support?

1. **High Strength:** Made from high grade steel, capable of supporting heavy loads.
2. **Flexible Configuration:** Can be adjusted to different heights and layouts.
3. **Quick Assembly & Disassembly:** The wedge lock system ensures fast setup.
4. **Long Life:** Hot dip galvanized for corrosion resistance and durability.
5. **Safe & Stable:** Meets global safety standards for secure load bearing applications.

This system is commonly used for bridge construction, high rise buildings, and large scale industrial projects, where stability and strength are crucial.

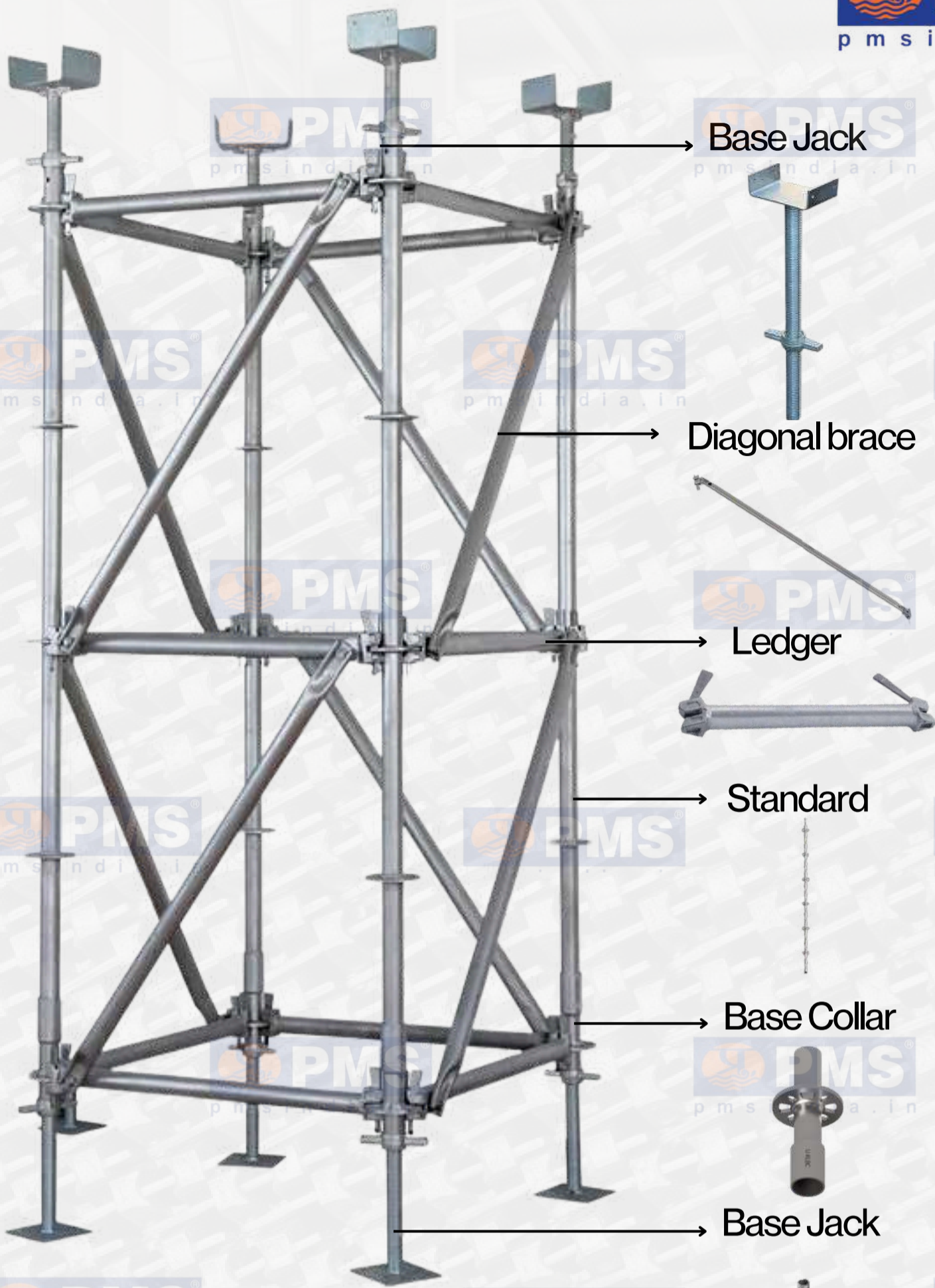

Components

1. Base Jack, U Jack & 4 Way Head Jack:

Adjusts height on uneven surfaces.

2. **Base Collar:** Initial connection for leveling.

3. **Standards:** Main load bearing structure.

4. **Ledgers:** Connect standards for support.

5. **Diagonal Braces:** Provide lateral stability.

Our 1.2m x 1.8m support tower offers a safe working load (SWL) of 4 tons per leg at a standard height of 4m-4.5m. Each tower features base and U-head screw jacks for precise adjustment and is reinforced with adequate ledgers and diagonal braces for structural integrity.



Key Advantages & Features

1. **Rapid Assembly & Dismantling:** Fewer components and an intuitive locking system for quick setup.
2. **Superior Strength & Stability:** Engineered for high load bearing capacity, ensuring structural security.
3. **Versatile & Adaptable:** Suitable for complex structures, high rises, bridges, and industrial sites.
4. **Cost Effective & Reusable:** Durable materials allow for repeated use, minimizing long term costs.
5. **Corrosion Resistant:** Up to 50 μm Hot dip galvanized steel enhances durability and prevents rust.
6. **Safety Certified:** Meets global construction standards for secure and reliable usage.
7. **Flexible Configurations:** Designed to support irregular and demanding construction needs.





Curved Ringlock Scaffolding for Complex Structures



Standard Ringlock Scaffolding for Versatile Applications

Rosette

A Ringlock system ring connects 4 ledgers and 4 diagonals, forming a strong, compact node. Uprights with rosette connectors have 8 punched holes, securing up to 8 bars and diagonals. Fastened with a hammer, it enables faster assembly than ratchet based systems.

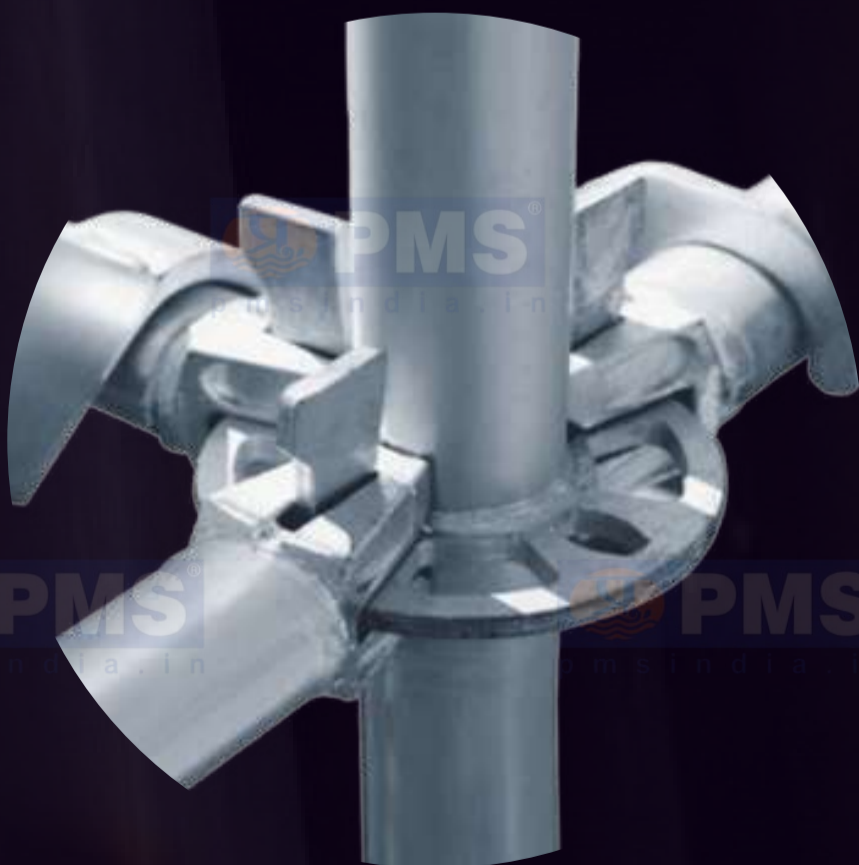

Base Jack, U Jack & 4 Way Head Jack

1. **Function:** Acts as the starting base for the scaffolding structure.
2. **Height Adjustment:** Features a threaded nut for precise vertical adjustments.
3. **Leveling Support:** Ensures the scaffold remains level and plumb on uneven surfaces.
4. **Load Distribution:** Helps distribute weight evenly for structural stability.
5. **Compatibility:** Designed for seamless integration with Ring Lock scaffolding.
6. **Material:** High strength steel for superior durability. 38mm diameter, 500mm length.
7. **Finish:** Hot dip galvanized to prevent corrosion and enhance longevity.

| Product Name | Outer Diameter (mm) | Length (mm) | Weight (kg) |
|------------------------|---------------------|-------------|-------------|
| Adjustable U Head Jack | 38 | 500 | 4.90 |
| Adjustable Base Jack | 38 | 500 | 3.50 |
| 4Way Screw Jack Head | 38 | 600 | 7.17 |

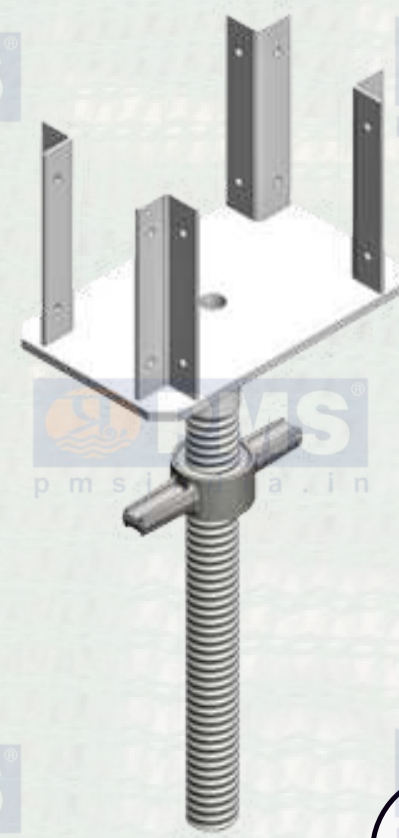
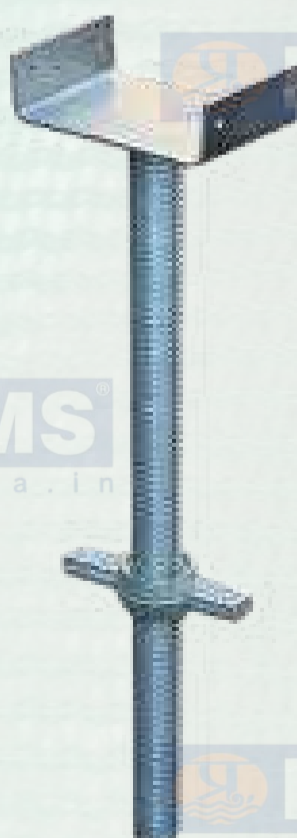

Hollow screw $\varnothing 38 \times 5$ mm
seamless steel pipe

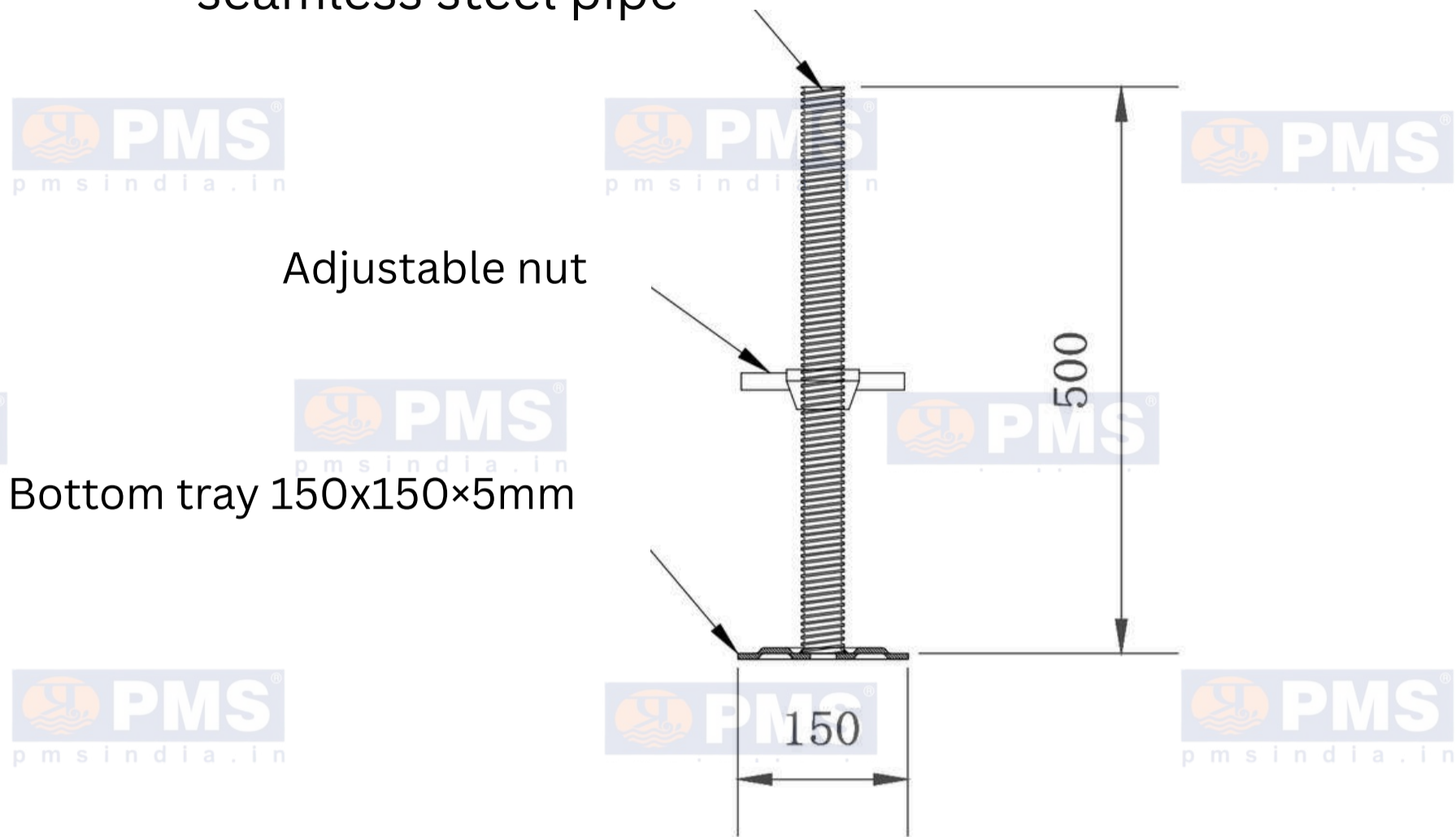

ADJUSTABLE BASE JACK

(BJ38500)

U Head 180x150x5mm

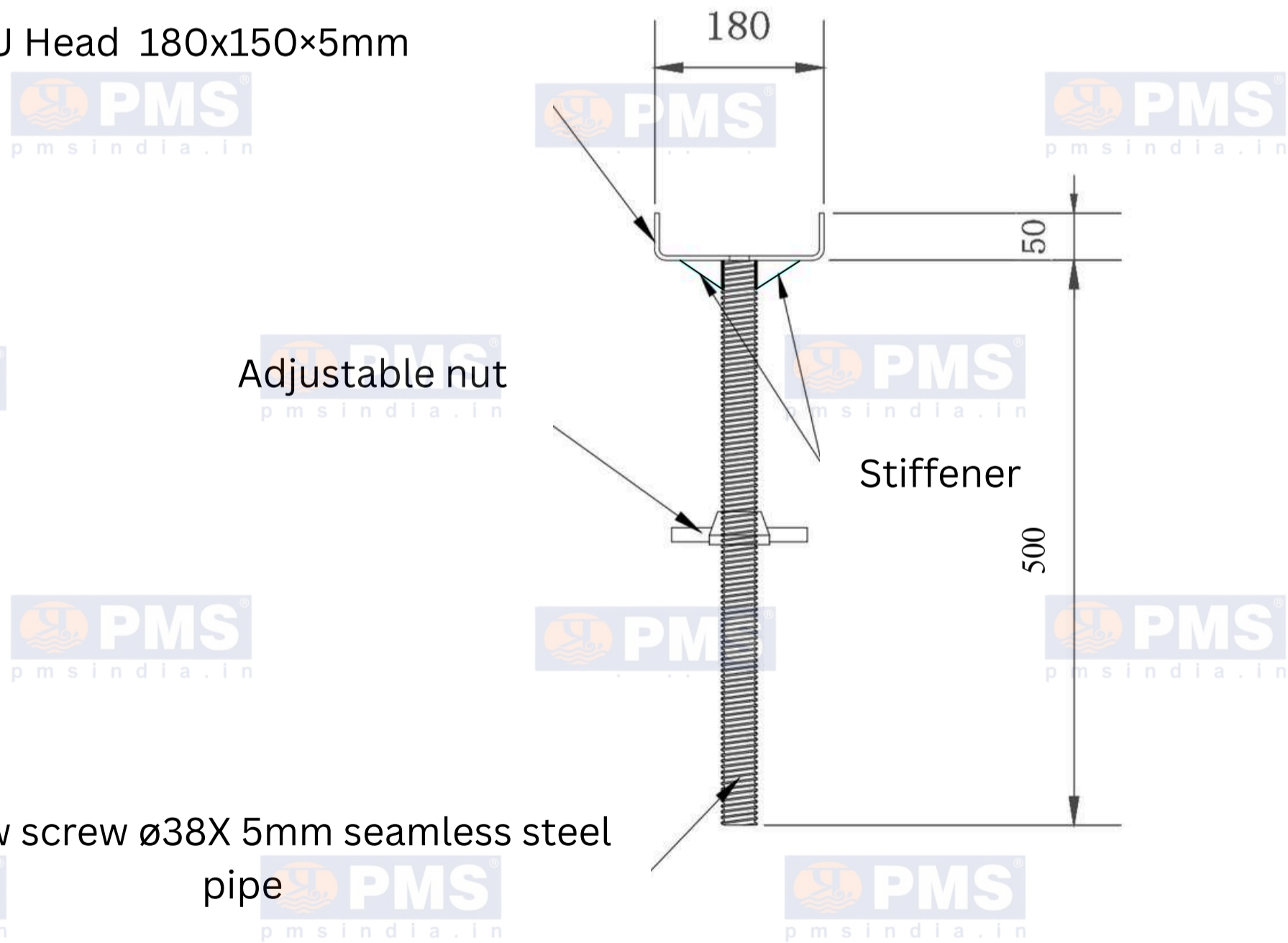

ADJUSTABLE U JACK

(UJ38600)

145

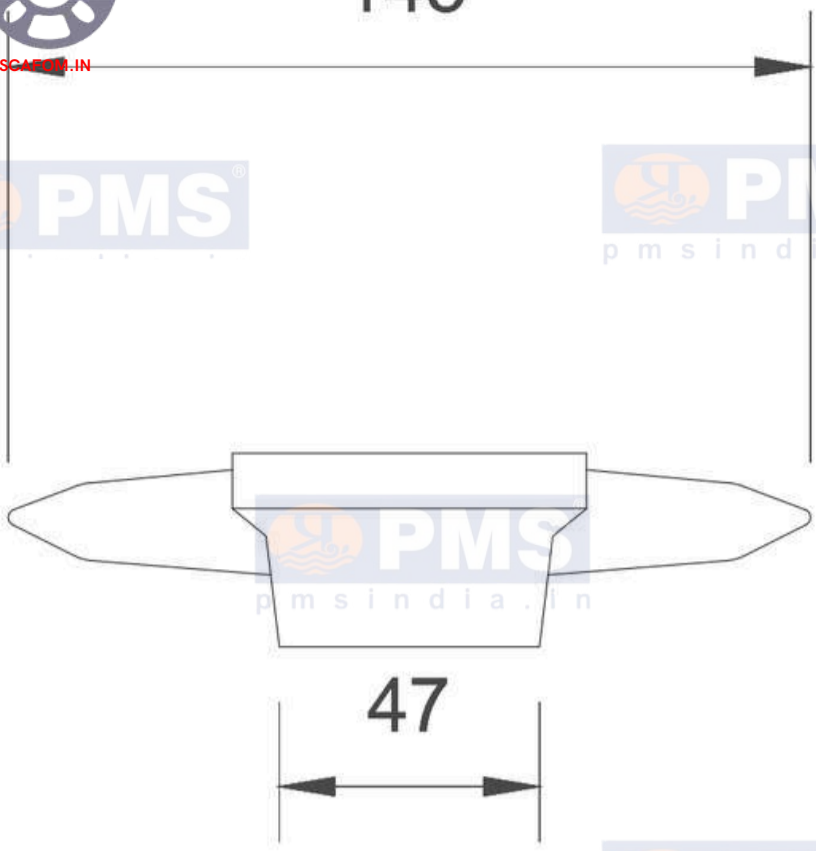

ELEVATION

145

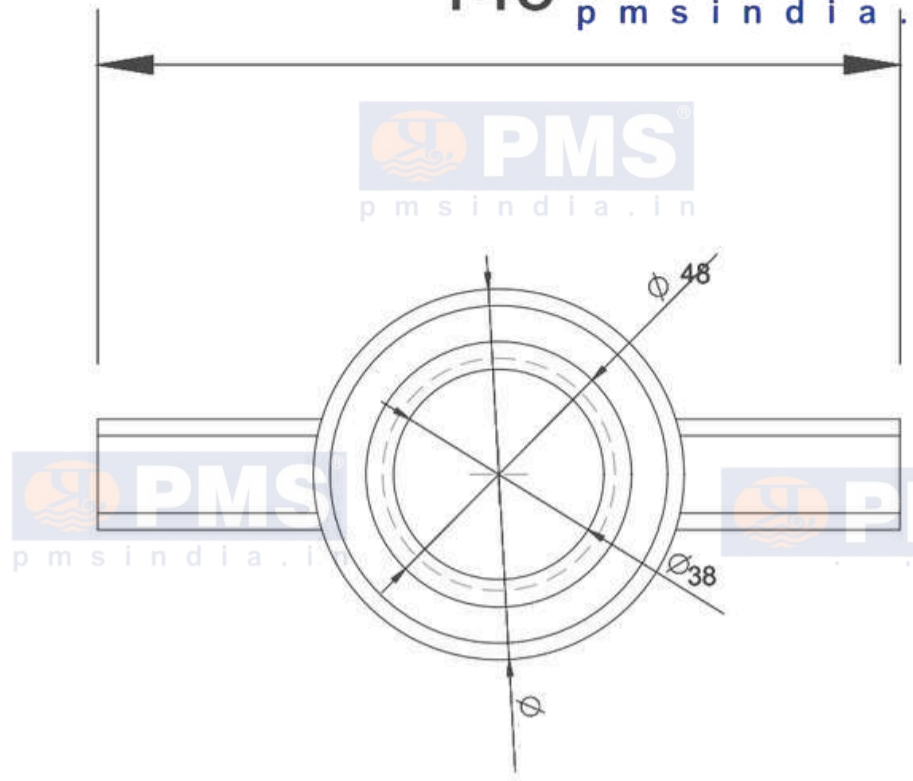

PLAN

ADJUSTABLE NUT (AN145)

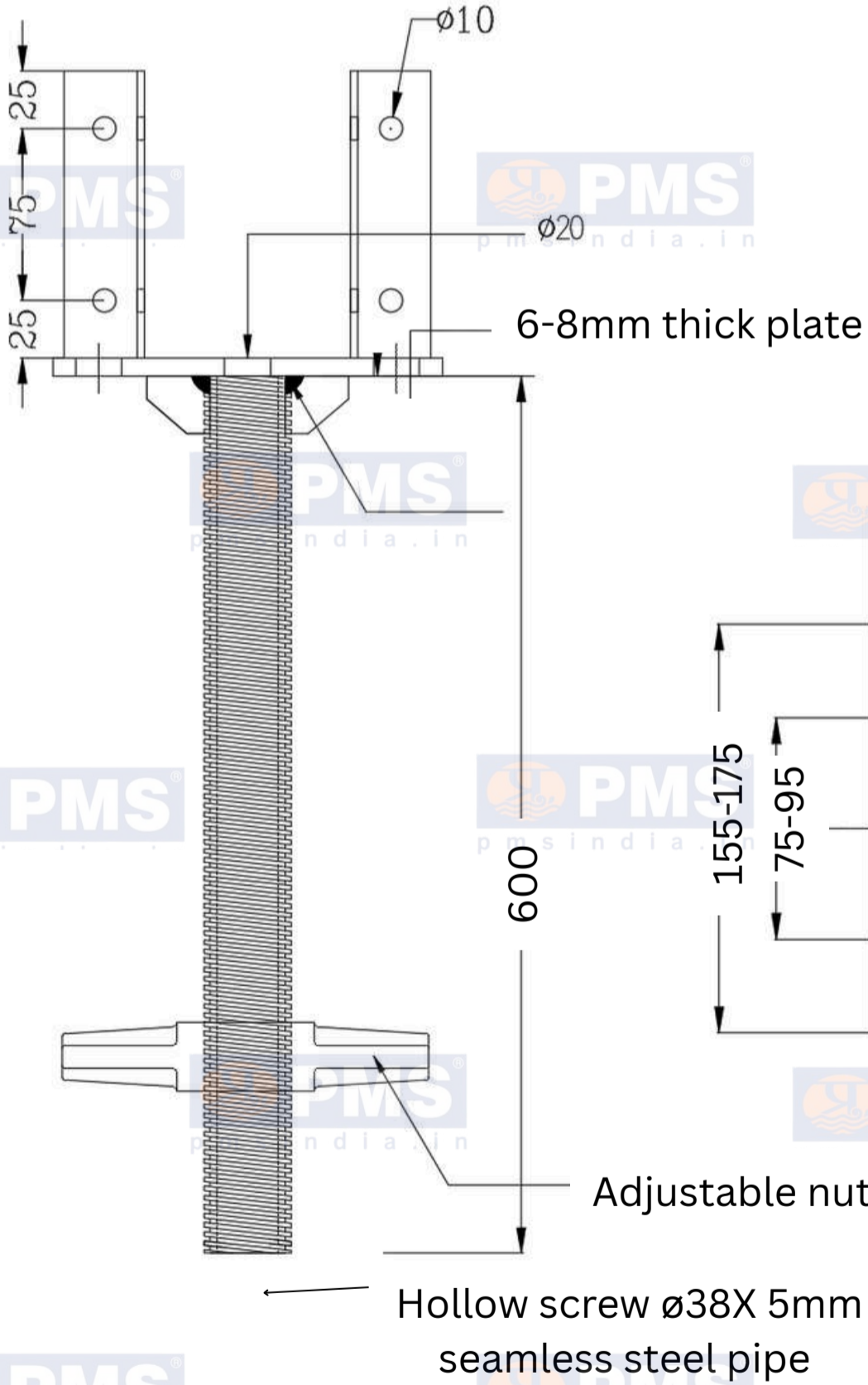

ELEVATION

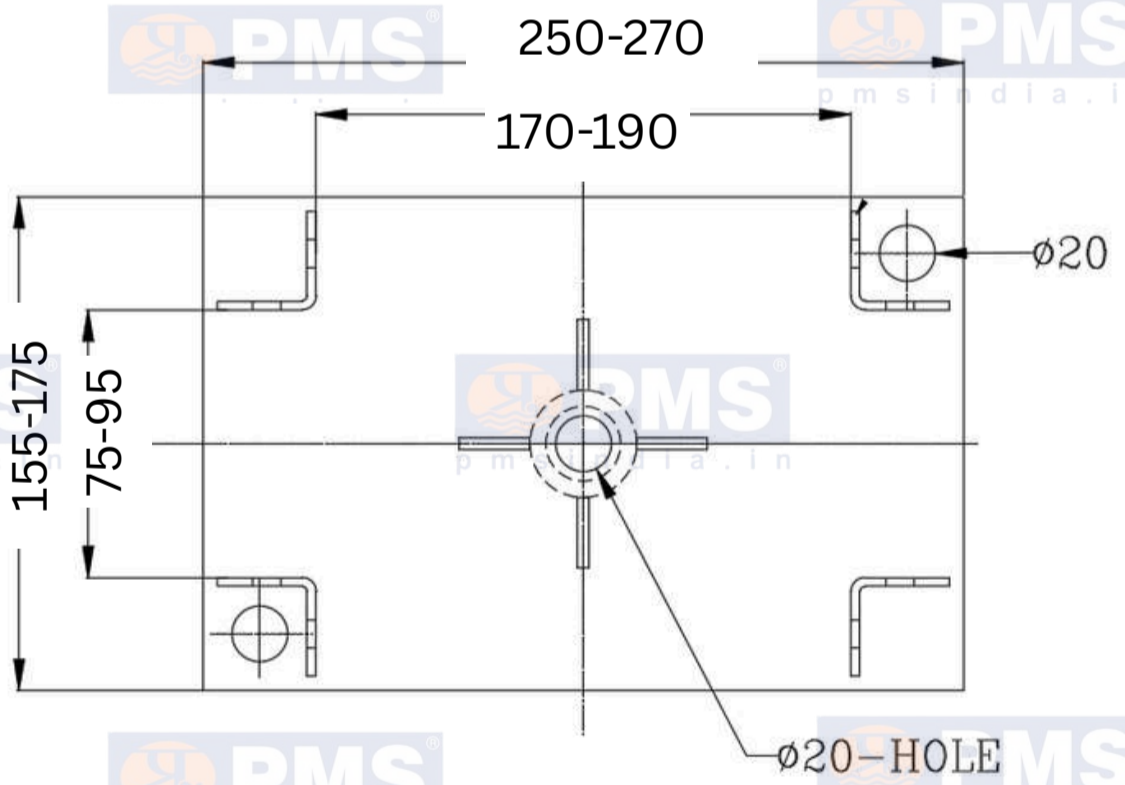

PLAN

4 WAY SCREW HEAD JACK (4WH)

Base Collar (Starter)

1. **Function:** Serves as the foundational component for Ring Lock scaffolding structures.
2. **Placement:** Sits on the base jack or swivel jack to provide initial support.
3. **Connection:** Enables secure attachment of ledgers for structural stability.
4. **Leveling Support:** Assists in squaring and leveling the scaffold framework.
5. **Structural Integrity:** Ensures a strong and stable foundation for the entire system.
6. **Compatibility:** Designed to integrate seamlessly with Ring Lock scaffolding.
7. **Material:** High strength steel for maximum durability. 48.3mm diameter, 3.2 mm thick, 0.25m length & 1.7kg weight.
8. **Finish:** Hot dip galvanized to resist corrosion and extend service life.



Ring Thickness 9.5mm

ø48.3 x 3.25

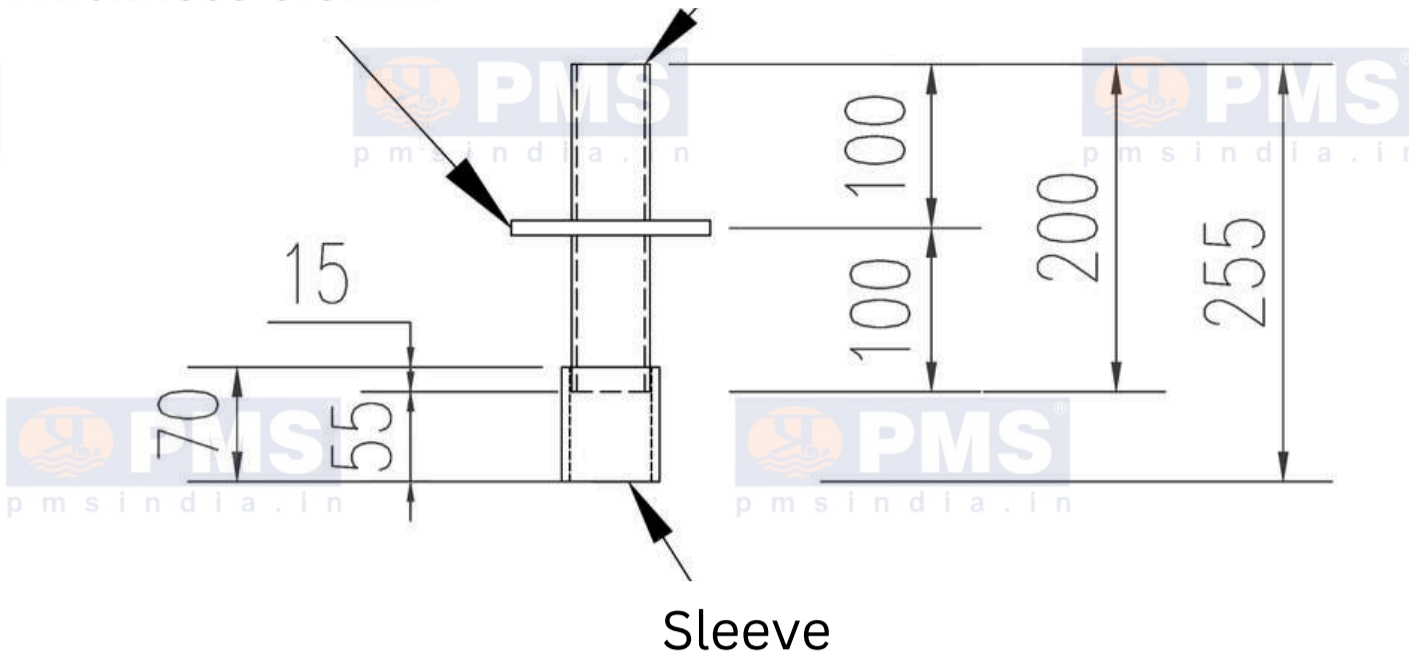

BASE COLLAR 200

(BC200)

ø48.3 x 3.25 Ring Thickness 9.5mm

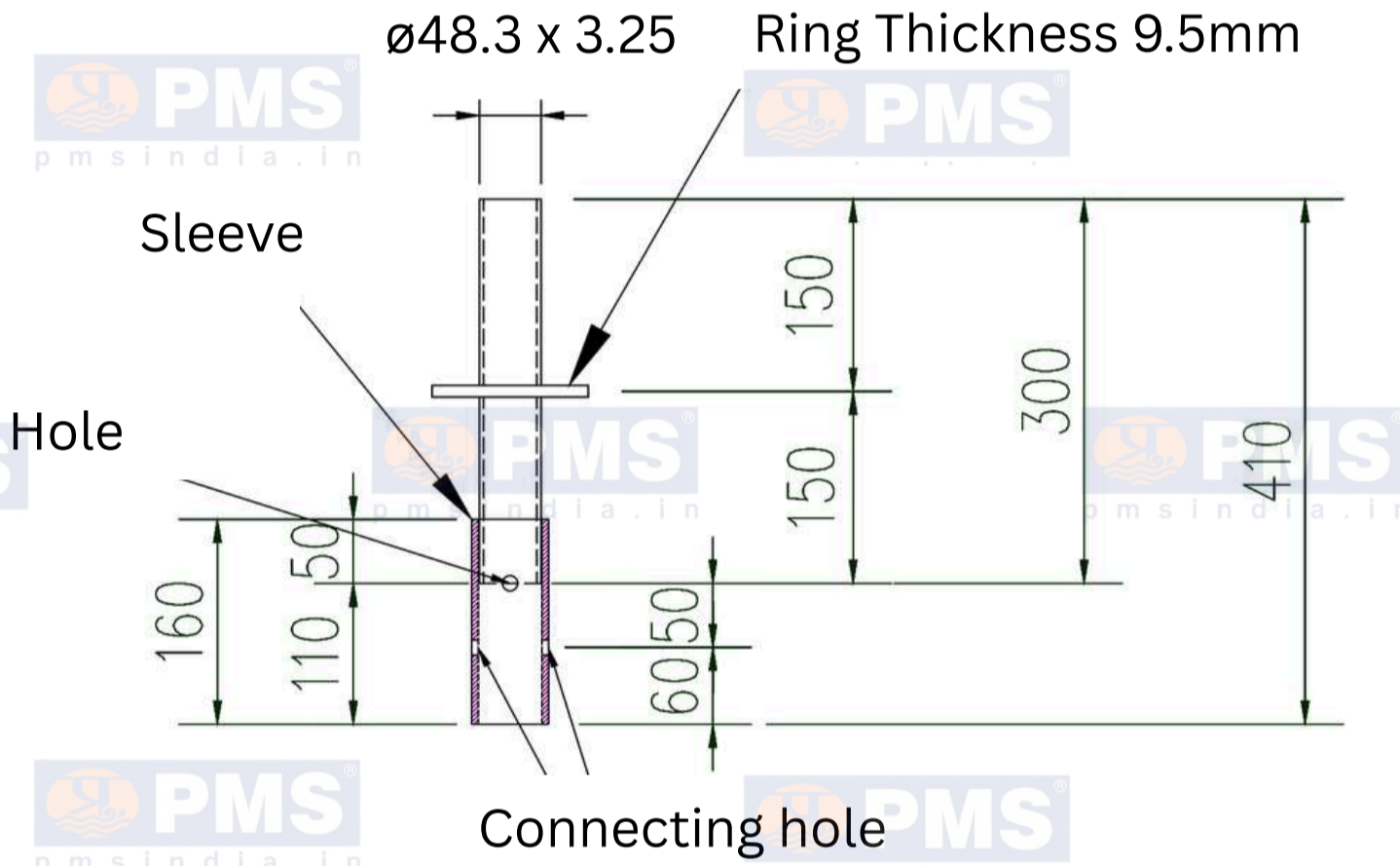

BASE COLLAR 300

(BC300)

ø48.3 x 3.25 Ring Thickness 9.5mm

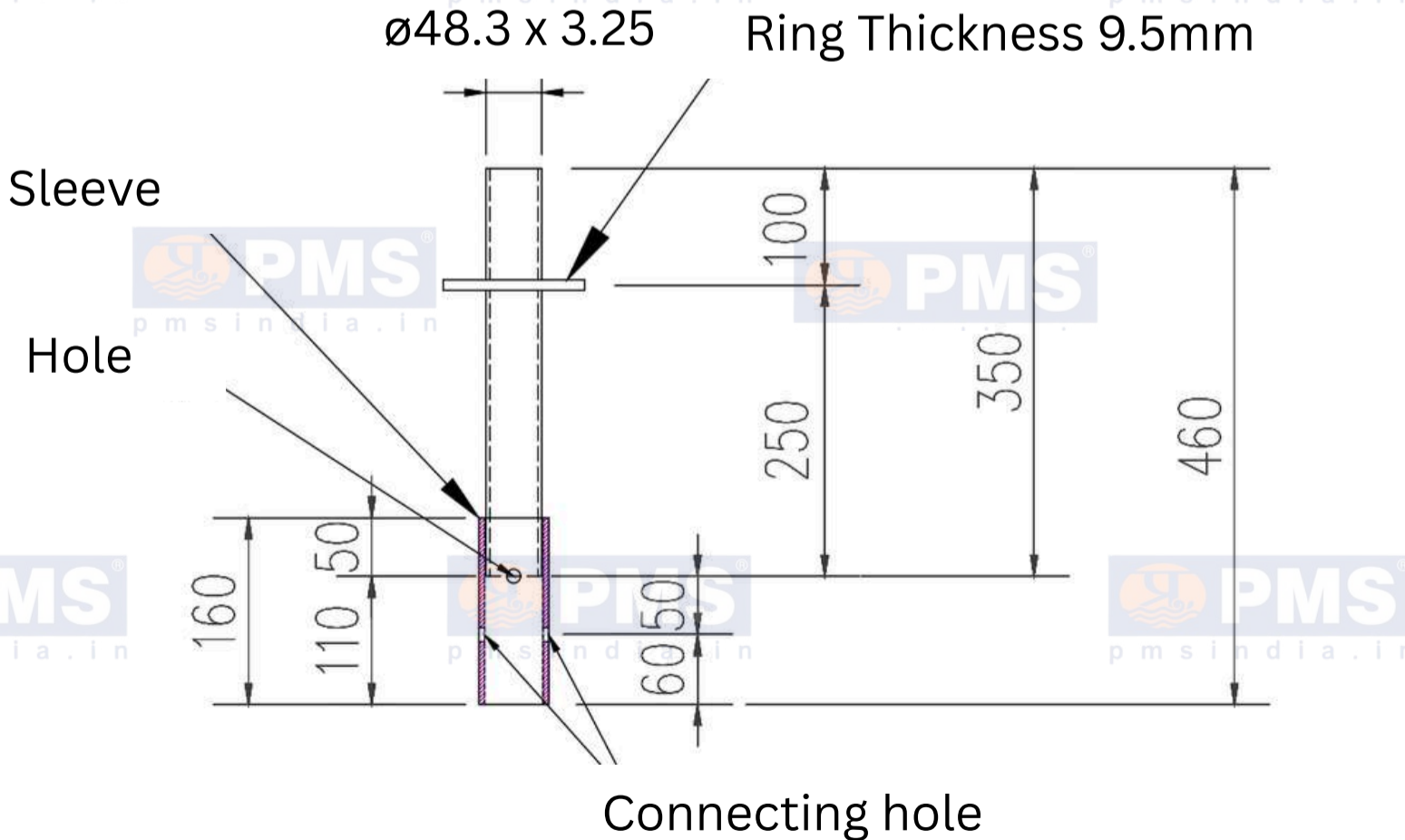

BASE COLLAR 350

(BC350)

Standards (Verticals)

1. **Function:** Primary vertical load bearing components in Ringlock scaffolding.
2. **Attachment Points:** Integrated rings/rosettes spaced every 500 mm (19.5") for secure connections.
3. **Material:** High strength 355 grade steel for enhanced durability and load capacity.
4. **Finish:** Hot dip galvanized for superior corrosion resistance.
5. **Design:** Fixed rosettes at intervals enable quick connection of ledgers and braces. Pipe $\text{Ø}48.3 \times 3.25$ mm with 9.5 mm rosette ring / disk thickness.
6. **Application:** Provides structural stability and support in scaffold assemblies.

| Size | Approx Weight (kgs) |
|----------------|---------------------|
| 3.0 m (9' 10") | 15.4 |
| 2.5 m (8' 2") | 13 |
| 2.0 m (6' 6") | 10.8 |
| 1.5 m (4' 11") | 8.5 |
| 1.0 m (3' 3") | 6.1 |
| 0.5 m (1' 7") | 3.8 |



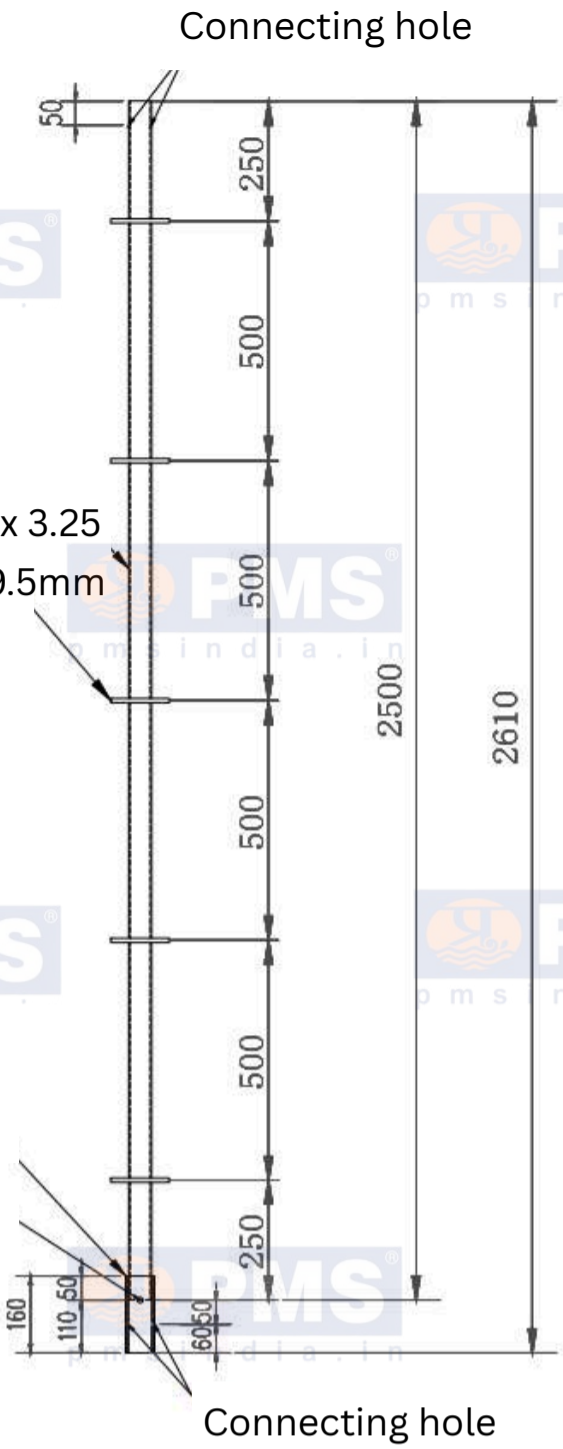

2500 VERTICAL STANDARD (VS2500)

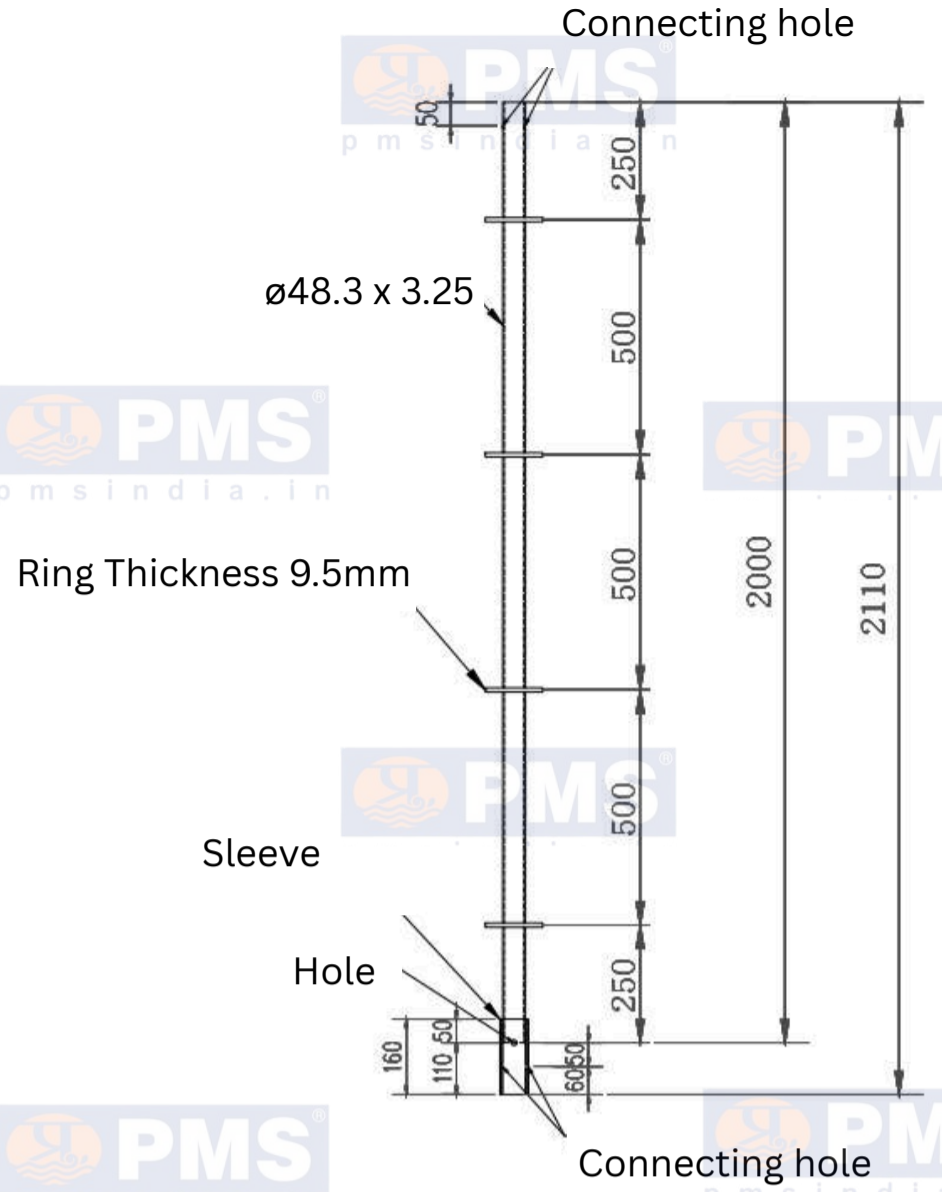

2000 VERTICAL STANDARD (VS2000)

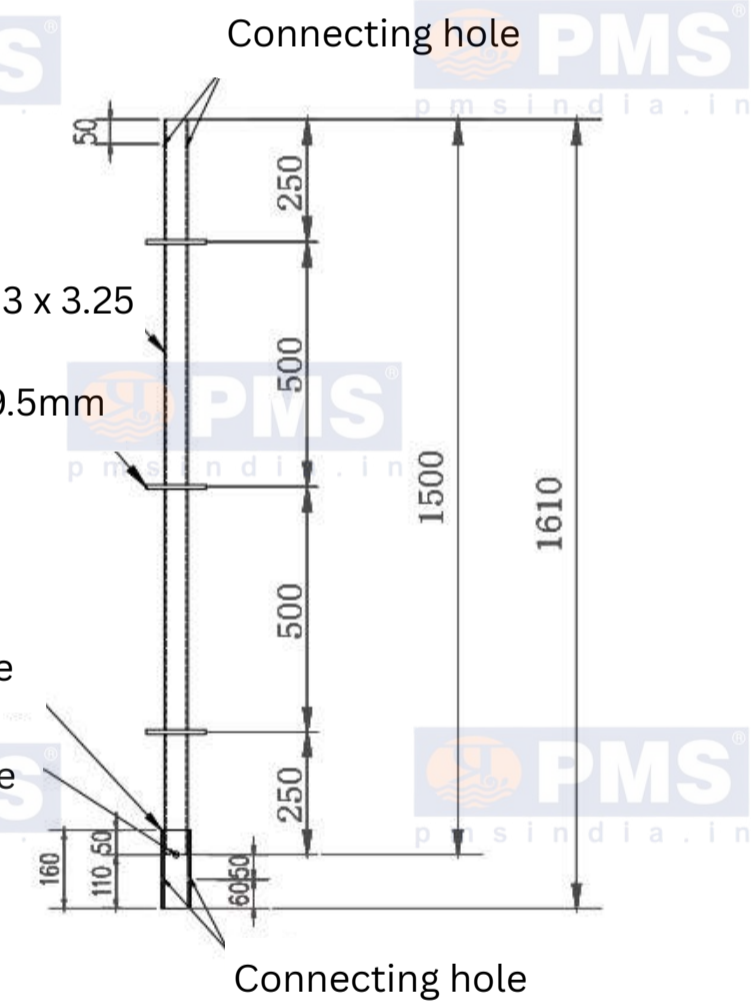

1500 VERTICAL STANDARD (VS1500)

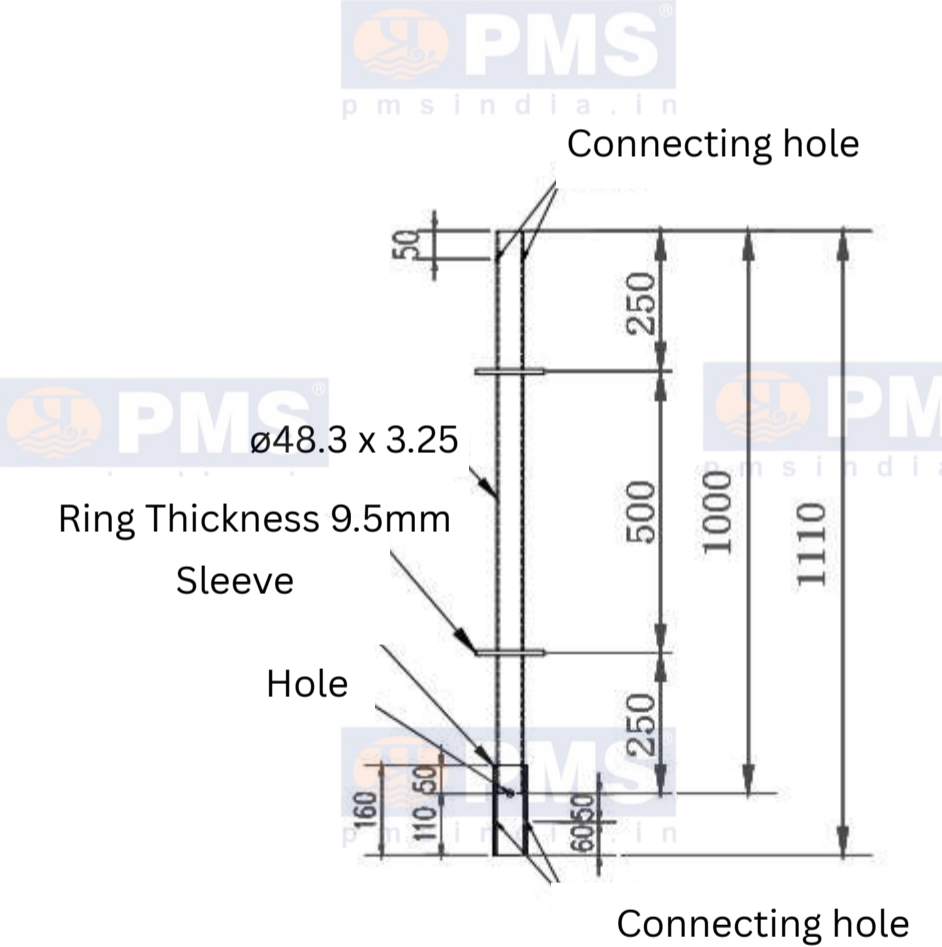

1000 VERTICAL STANDARD (VS1000)

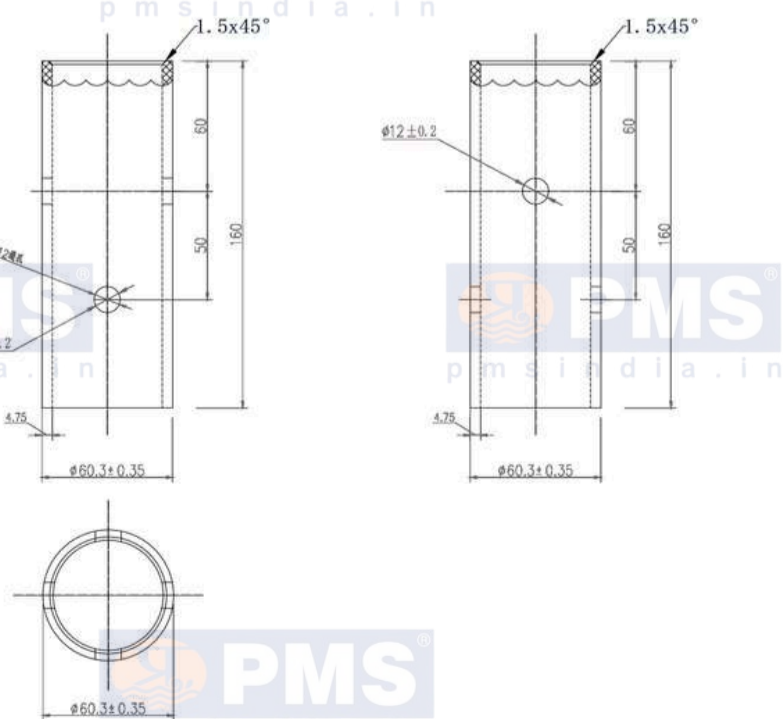

OUTER SLEEVE (OS)



RINGLOCK SPIGOT (RS)

Ledgers (Horizontal)

1. **Function:** Horizontal members that define the scaffold bay width and provide structural support.
2. **Connection:** Attach to standards at multiple levels, ensuring stability.
3. **Dual Purpose:**
 - Ledgers:* Act as horizontal support beams and serve as top rails and mid rails in guardrail systems.
 - Transoms:* Shorter ledgers that support planks and create a stable walking surface.
4. **Recommended Use:** For bays 6 feet or wider, a double ledger is advised as a transom for enhanced strength.
5. **Material:** High strength steel for durability and load bearing capacity. 48.3mm diameter, 2.75mm thick.
6. **Finish:** Hot dip galvanized to prevent corrosion and extend lifespan.



Ledgers (Horizontal)

| Size (m & ft) | Weight (kg) |
|---------------|-------------|
| 0.6m (2' 0") | 2.46 |
| 0.9m (3' 0") | 3.35 |
| 1.2m (4' 0") | 4.32 |
| 1.5m (5' 0") | 5.26 |
| 1.8m (6' 0") | 6.34 |

- 1. Multi Directional Load Bearing:** Supports horizontal loads while contributing to overall scaffold rigidity.
- 2. Integration with Diagonal Braces:** Works with diagonal braces to create stable, triangulated structures.
- 3. Curved Structures:** Enables radial or circular scaffolding by adjusting connection angles.
- 4. Optimized Load Distribution:** Multiple ledgers connect at a single rosette, ensuring even weight distribution and high load capacity.
- 5. Suspended Scaffold Configurations:** Supports hanging scaffolds for bridge or industrial maintenance work.
- 6. Quick Modular Assembly:** Standardized connection points allow for faster assembly and disassembly.
- 7. Hybrid Structures:** Can be used with tube and coupler scaffolding for custom applications.



Center line

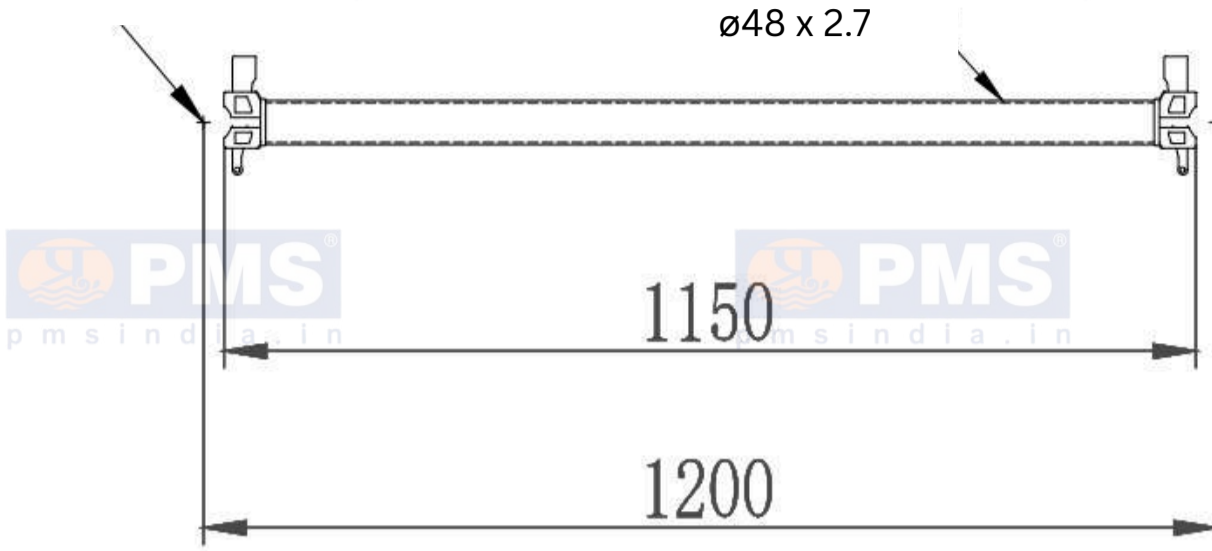

1200 HORIZONTAL LEDGER

(HL1200)

Center line

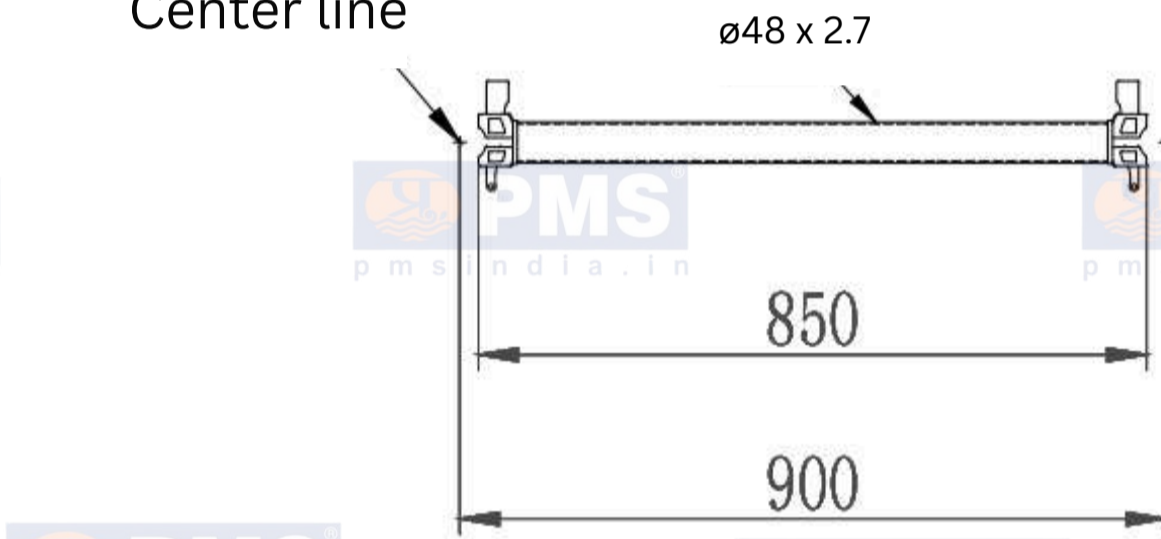

900 HORIZONTAL LEDGER

(HL900)

Center line

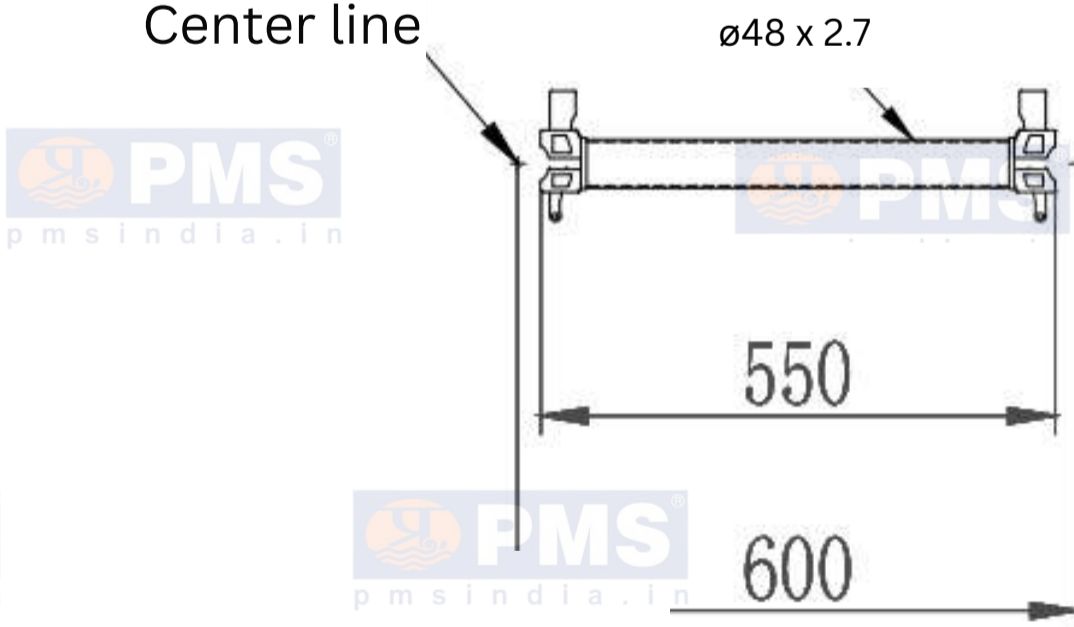

600 HORIZONTAL LEDGER

(HL600)

Diagonal Braces (Bay Braces)

1. **Function:** Enhances lateral stability and reinforces the structural integrity of the scaffolding system.
2. **Connection:** Securely attaches between standards and ledgers to prevent sway and movement.
3. **Dual Purpose:**
 - *Structural Support:* Stiffens the scaffold to maintain rigidity.
 - *Handrails & Mid Rails:* Serves as safety rails when used with stair systems.
4. **Structural Stability & Load Resistance:** Prevents lateral movement and enhances stability, ensuring rigidity in high load and outdoor applications.
5. **Optimal Placement:** Install at regular intervals for maximum structural integrity.
6. **Compatibility:** Seamlessly integrates with ring lock scaffold systems.
7. **Material:** High strength steel for superior durability. 42.3mm diameter, 2.5mm thick.
8. **Finish:** Pre Galvanized pipe to resist corrosion and extend service life.

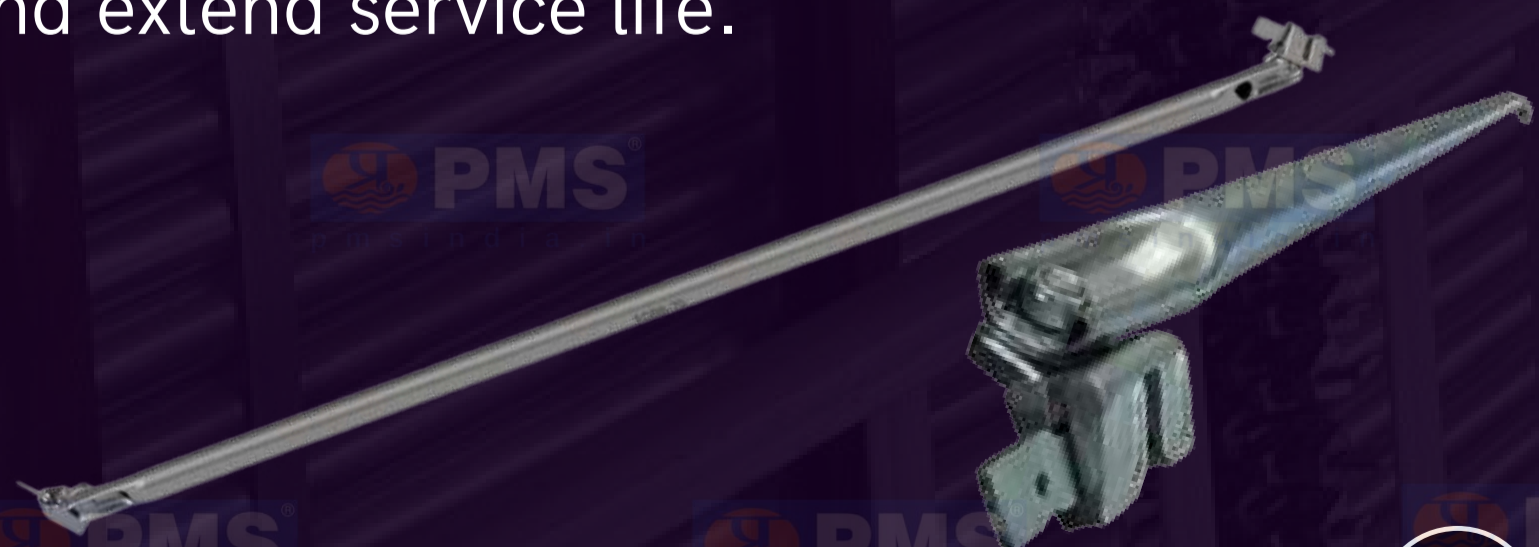

Diagonal Braces (Bay Braces)

DIAGONAL BRACE 1.5M HEIGHT

| Bay Size (mm) | Weight (kg) |
|---------------|-------------|
| 600 × 1500 | 5.4 |
| 900 × 1500 | 5.6 |
| 1200 × 1500 | 6.1 |
| 1500 × 1500 | 6.5 |
| 1800 × 1500 | 7.2 |

DIAGONAL BRACE 2.0M HEIGHT

| Bay Size (mm) | Weight (kg) |
|---------------|-------------|
| 600 × 2000 | 6.8 |
| 900 × 2000 | 7.1 |
| 1200 × 2000 | 7.3 |
| 1500 × 2000 | 7.7 |
| 1800 × 2000 | 8.1 |

- 1. Triangulation for Strength:** Forms rigid triangular patterns that improve load bearing capacity.
- 2. Multi Level Bracing:** Provides reinforcement at various heights for tall scaffolding systems.
- 3. Curved and Angled Structures:** Enables scaffolding for circular or irregularly shaped structures.
- 4. Wind and Seismic Resistance:** Strengthens the scaffold against external forces like wind and vibrations.



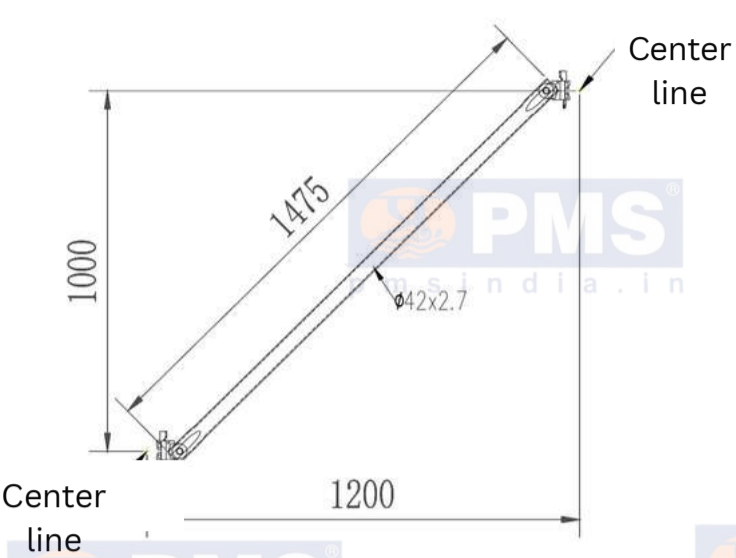

1200×1000 DIAGONAL BRACE
(DB12001000)

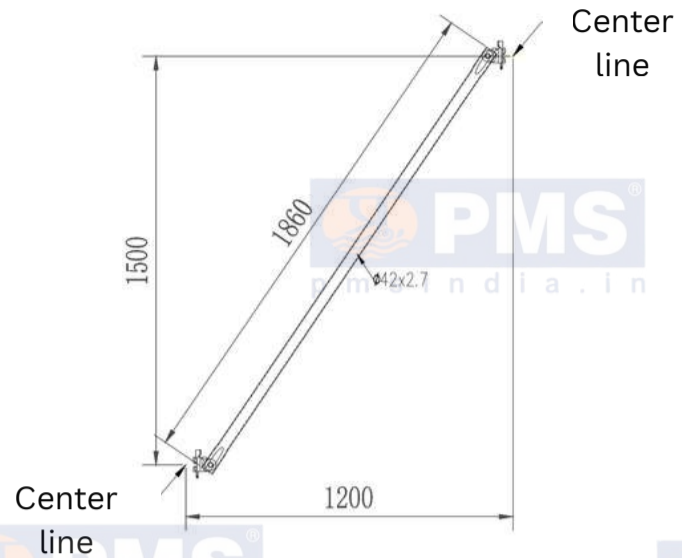

1200×1500 DIAGONAL BRACE
(DB12001500)

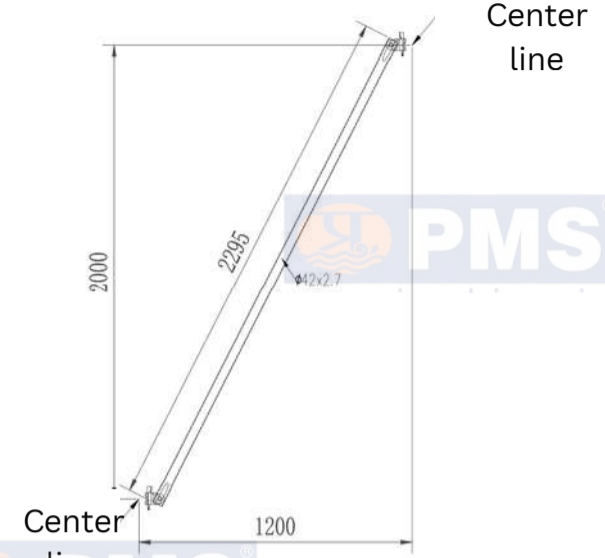

1200×2000 DIAGONAL BRACE
(DB12002000)

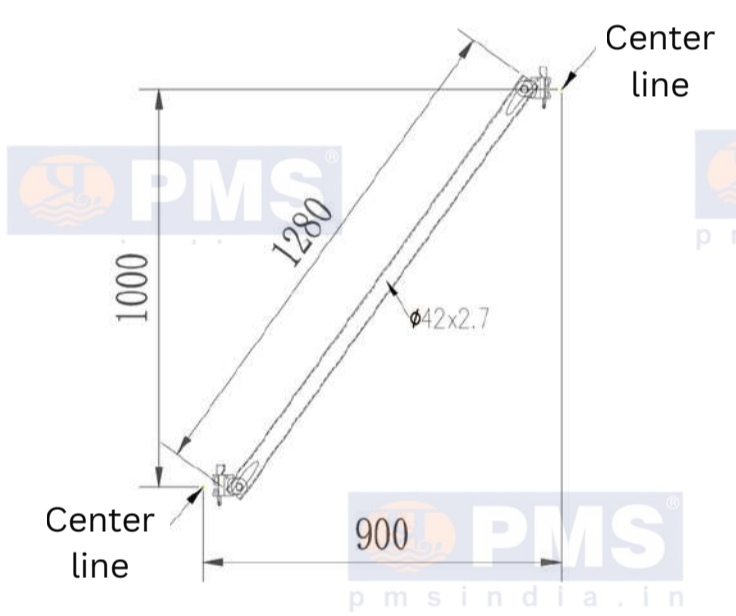
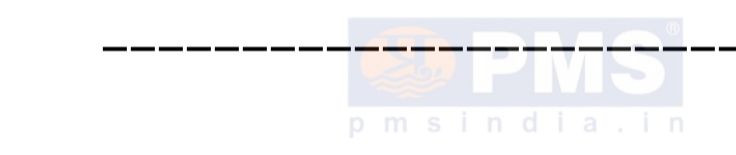

900×1000 DIAGONAL BRACE
(DB9001000)

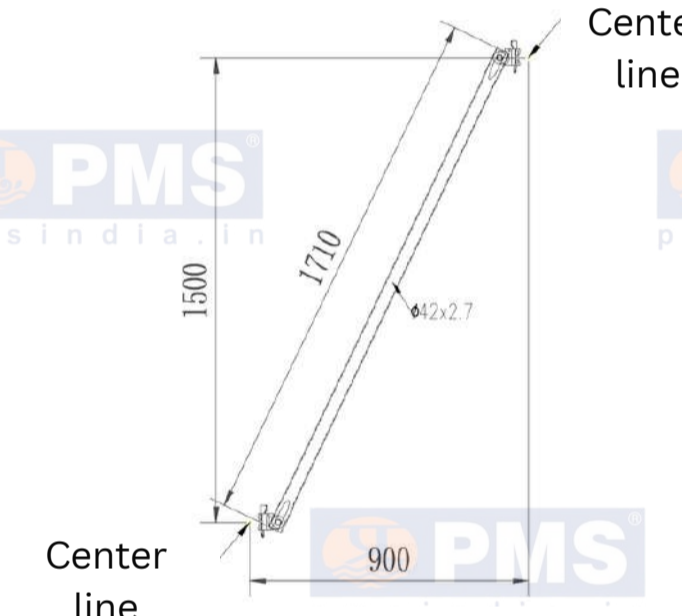

900×1500 DIAGONAL BRACE
(DB9001500)

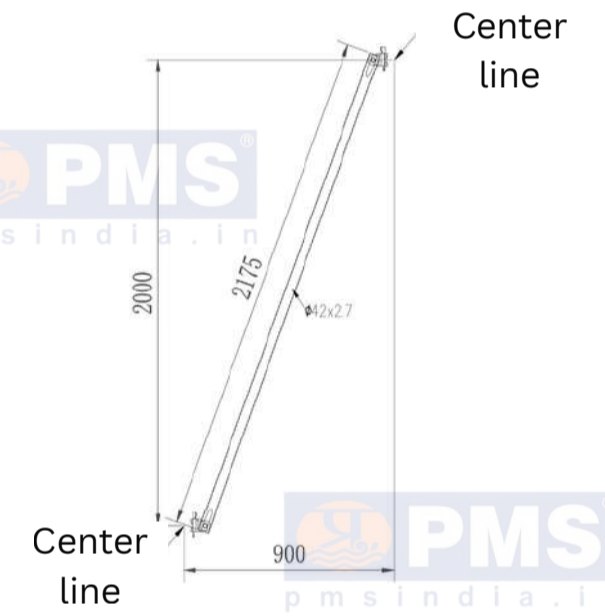

900×2000 DIAGONAL BRACE
(DB9002000)

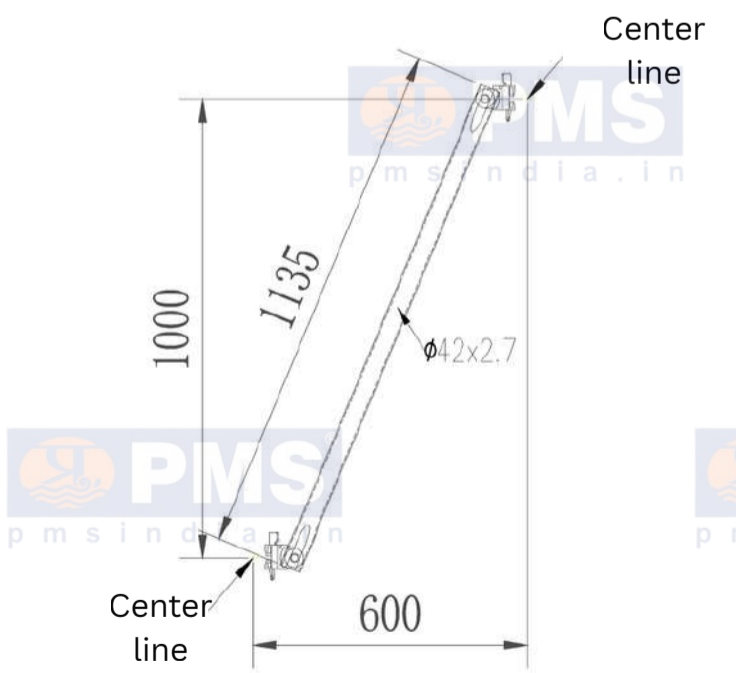

600×1000 DIAGONAL BRACE
(DB6001000)

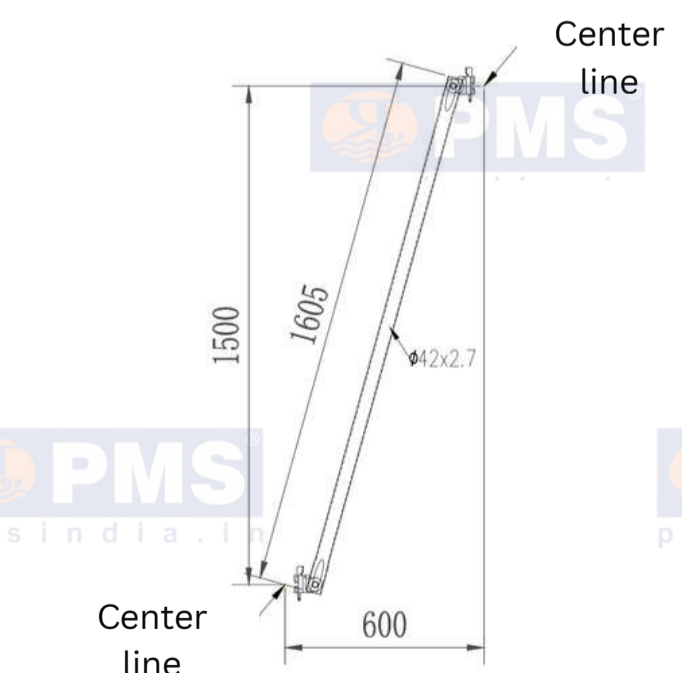

600×1500 DIAGONAL BRACE
(DB6001500)

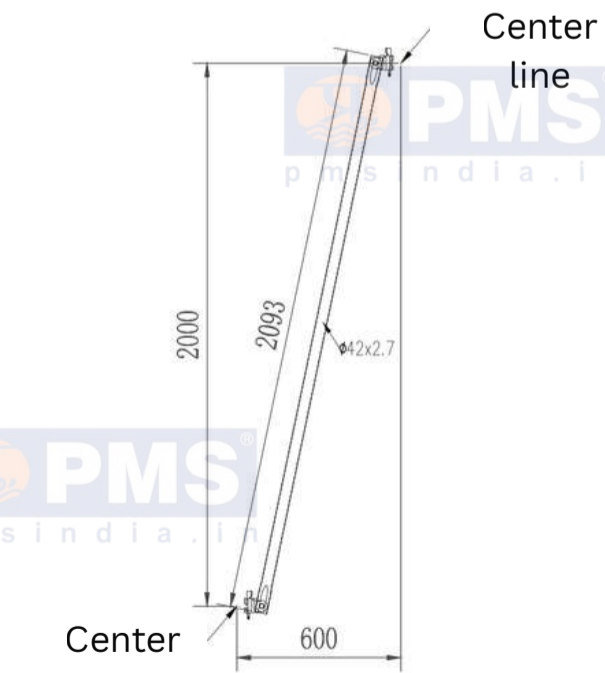

600×2000 DIAGONAL BRACE
(DB6002000)





SCAFOM

SCAFOM.IN

**PMS Scaffolding
Services:**

**End to End
Solutions**

Design & Engineering

1. Scaffolding Layout & Load Calculations – Ensuring safety & stability
2. Custom Drawings & 3D Models – GA, elevation & connection details
3. BIM Integration (4D & 5D) – Planning, cost estimation & coordination
4. Formwork & Temporary Structure Design – Tailored for every project
5. Tower to Tower Load Analysis – Preventing overload risks
6. Customized Temporary Access Solutions – Safe worksite access
7. Structural Analysis & Wind Load Calculations – Ensuring compliance
8. Client Specific Scaffolding Design – Meeting unique project needs



Scaffolding Supply & Rental

1. Certified Scaffolding Materials – Steel
2. On Demand Rental Services – Short & long term leasing options
3. Optimized Material Turnaround – Reducing downtime & costs
4. Comprehensive Scaffolding Kits – Including accessories & safety elements
5. Fast Deployment & Logistics – Ensuring timely delivery
6. Customized Rental Plans – Flexible pricing & usage based solutions
7. Material Quality Assurance – Regular checks for durability & safety
8. Multi Site Scaffolding Supply – Supporting large scale projects



Erection & Dismantling

1. **PMS is the only Certified E&D partner with PERI in India.**
2. **Expert Scaffolding Installation & Inspection** – By trained & certified professionals
3. **Controlled Dismantling Procedures** – Safe & efficient removal
4. **Just in Time Execution** – Reducing project delays
5. **On Site Modifications** – Adjustments for design or safety changes
6. **Temporary Structures & Bridges** – Custom solutions for worksite access
7. **Load Distribution Monitoring** – Preventing structural failures
8. **Rapid Mobilization & Deployment** – Supporting high speed projects
9. **Integrated Safety Protocols** – Compliance with global standards



Safety & Compliance

1. TATA Steel LTD 4 Star Safety Certification – Industry recognized safety rating
2. Pre Installation & Post Installation Safety Inspection – Ensuring risk free scaffolding
3. Daily & Weekly Safety Audits – Monitoring compliance & best practices
4. Work Permit & Compliance Management – Digital approvals via ORECS
5. PPE & Worker Safety – Helmets, harnesses & strict safety protocols
6. Fall Protection Systems – Guardrails, lifelines & netting solutions
7. Continuous Safety Training – Keeping workers updated & compliant



Complete Scaffolding Lifecycle Management

1. Site Assessment & Material Mobilization – Pre planning for smooth execution
2. Storage & Inventory Control – Preventing damage & theft
3. On Site Logistics & Just in Time Delivery – Efficient material movement
4. Inspection & Quality Checks – Ensuring scaffold stability
5. Maintenance & Repairs – Extending the lifespan of scaffolding materials
6. Material Reuse & Recycling – Sustainable, cost effective operations
7. Post Dismantling Site Cleanup – Maintaining a safe workspace
8. End to End Project Documentation – Digital tracking from start to finish



Smart Scaffolding Management (Powered by ORECS)

1. Real Time Monitoring & Tracking – Digital control of manpower & materials
2. Automated Inspection Scheduling – Improving compliance & safety
3. Work Permit & Incident Reporting – Streamlining approvals & safety documentation
4. Inventory & Logistics Optimization – Preventing material shortages & waste
5. Productivity Analytics & Reports – Data driven performance insights
6. Centralized Workforce Allocation – Efficient distribution of scaffolders



Conclusion

1. **Versatile & Modular:** Adapts to complex structures with ease.
2. **Quick Assembly & Dismantling:** Saves time with an intuitive locking system.
3. **High Load Capacity:** Engineered for maximum strength and stability.
4. **Corrosion Resistant:** Hot dip galvanized for long term durability.
5. **Cost Effective & Reusable:** Reduces long term expenses with durable materials.
6. **Safety Compliant:** Meets global construction safety standards.
7. **Ideal for Various Applications:** Suitable for industrial, commercial, and high rise projects.



Building Together

Scaffolding isn't just support—it's trust, strength, and progress. Like a solid scaffold, we stand by our clients, ensuring stability at every stage.

1. **Strong Foundations** – Every great project starts with trust and reliability.
2. **Rising Together** – As scaffolding lifts structures, we elevate our clients' success.
3. **Unwavering Support** – Through challenges, we stay steady and adaptable.
4. **Built to Fit** – Just like our scaffolding, our partnerships adjust to every need.
5. **Beyond the Build** – Even after the project, our support remains.

Together, we build, rise, and achieve.



Contact Us



+91 98252 11788



prakash@pmsindia.in



scafom.in



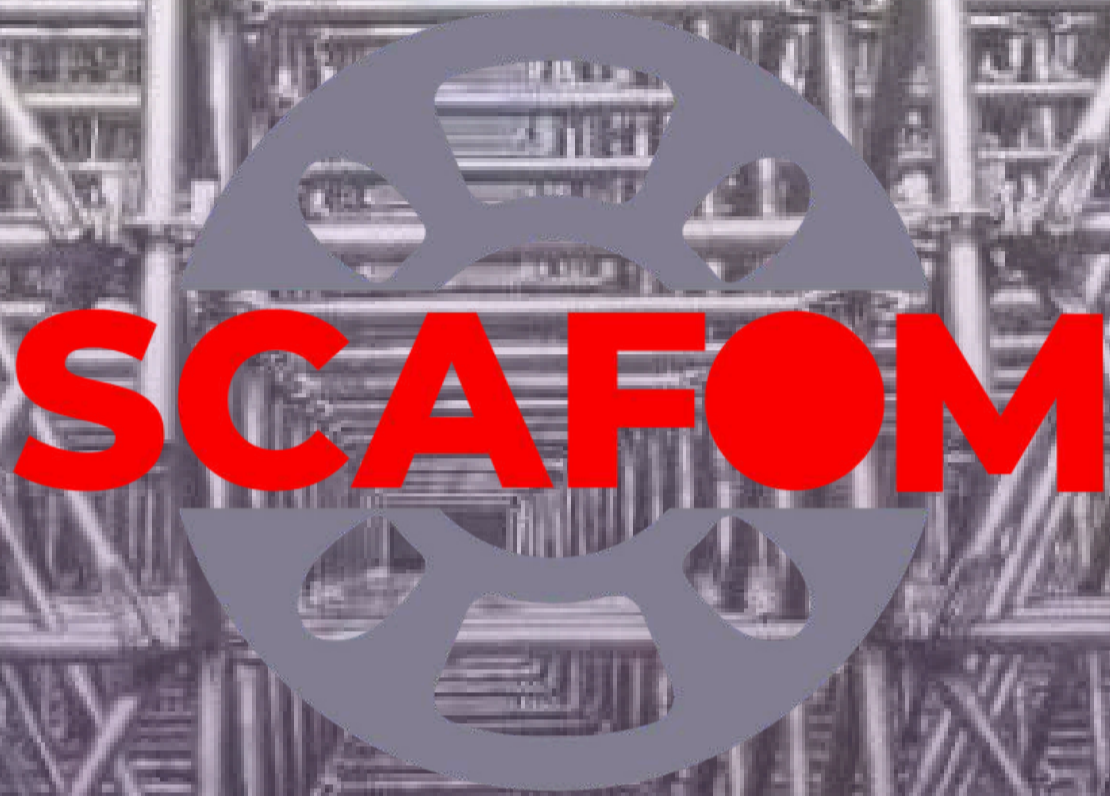

SCAFOM.IN

Thankyou.